



# WHEEL CYLINDERS

## NUMERICAL INDEX & BUYERS' GUIDE—cont.

**Front & Rear = 400 to 402    Front = 403 and Arnolt**

Assembly No.	Cylinder Dia.	Fig.	Repair Kit	APPLICATION	Alternative Assembly
25452 Front	1½"	BP.5		Allard, Alvis, Armstrong, Siddeley, Austin, Beardmore, Bristol, Frazer Nash, Healey, Humber, Jaguar, Lagonda, Smith's N.C.B. Electric, Sunbeam-Talbot, Trojan, Wolseley	
25453 Rear	1½"	BX.11	KL.71470	Allard, Armstrong Siddeley, Austin, Bristol, Frazer Nash, Healey, Humber, Lagonda, Lister, Morris Commercial, Morrison Electricars, Seddon, Sunbeam-Talbot, Trojan, Wales & Edwards	

The rear wheel cylinders for 403 - 405 are not listed in the Lockheed Catalogue, it just says they are specials. It is possible that the 403 number is 4243-420 and as they use the same front cylinder, it is also possible that Arnolt's are the same but all of this needs to be verified and cross-checked.

For 405 / 6 comments see the front wheel cylinder.

# WHEEL CYLINDER SINGLE-ENDED TYPE



Figure  
**BP**  
VOLUME 2. Page 15

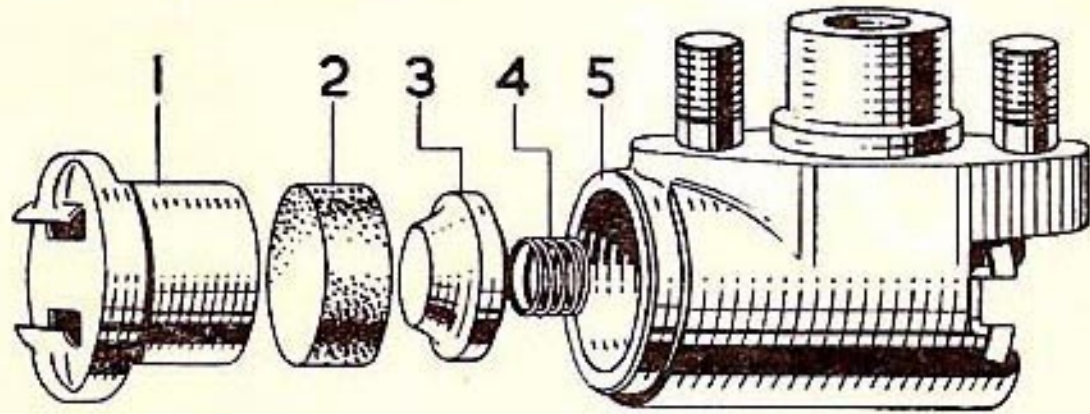

25452  
Front  
400-403  
& Arnolt

Description	BP1— $\frac{7}{8}$ "	BP2— $\frac{7}{8}$ "	BP3— $\frac{7}{8}$ "	BP4—1"	BP5—1 $\frac{1}{8}$ "
	Part No.	Part No.	Part No.	Part No.	Part No.
Assembly	30357 RH	30358 LH	30284	25451	25452
1. Piston and Dust Cover	24626	24627	25277	23515	22619
2. Cup	586	586	586	131	2762
3. Cup Filler	29574	29574	29574	30053	29660
4. Spring	29368	29368	29368	29368	30977
5. Cylinder Body	25407	25408	25300	25411	25410
<b>Suitable Pipe Connections</b>					
Inlet Banjo Bolt	21992	21992	21992	7964	7964
Inlet Banjo Bolt	94011	94011	94011	10543	10543



**OLD DESIGN**

Description	BX1— $\frac{7}{8}$ "	BX2— $\frac{7}{8}$ "	BX3— $\frac{7}{8}$ "	BX4— $\frac{7}{8}$ "	BX5— $\frac{7}{8}$ "	BX6— $1\frac{1}{8}$ "	BX7— $1\frac{1}{8}$ "	BX8— $1\frac{1}{8}$ "
	Part No.	Part No.	Part No.	Part No.	Part No.	Part No.	Part No.	Part No.
Assembly	22607	†30285	*30359	††30776	31968	29643	†28175	30241
1. Handbrake Lever	21693	27785	27785	24259	31967	**	28174	28174
2. Boot	★ 27699	27699	27699	27699	27699	21740	21740	21740
3. Cylinder Body	25301	25301	25301	25301	25301	25409	25409	25409
4. Spring	29368	29368	29368	29368	29368	30977	30977	30977
5. Cup Filler	29574	29574	29574	29574	29574	29660	29660	29660
6. Cup	★ 586	586	586	586	586	30149	2762	30149
7. Piston (Hydraulic)	21692	21692	21692	21692	21692	21735	21735	21735
8. Sealing Ring	★ 93858/14	93858/14	93858/14	93858/14	93858/14	93858/19	93858/19	93858/19
9. Piston and Dust Cover	36467	36332	36467	36332	36332	38219	38219	38219
10. Pivot Pin	36185	36185	36185	36185	36185	21737	21737	21737
<b>Suitable Pipe Connections</b>								
Inlet Banjo Bolt	21992	21992	21992	21992	21992	7964	7964	7964
Inlet Banjo Bolt	94011	94011	94011	94011	94011	10543	10543	10543
Repair Kit	★ KL.71469	KL.71469	KL.71469	KL.71469	KL.71469	KL.71486	KL.71470	KL.71486
*****								
Description	BX9— $1\frac{1}{8}$ "	BX10— $1\frac{1}{8}$ "	BX11— $1\frac{1}{8}$ "					
	Part No.	Part No.	Part No.					
Assembly	30962	31406	25453					
1. Handbrake Lever	30961	25251	25251					
2. Boot	★ 21740	21740	21740					
3. Cylinder Body	25409	25409	25409					
4. Spring	30977	30977	30977					
5. Cup Filler	29660	29660	29660					
6. Cup	★ 30149	30149	2762					
7. Piston (Hydraulic)	21735	21735	21735					
8. Sealing Ring	★ 93858/19	93858/19	93858/19					
9. Piston and Dust Cover	38219	38219	38219					
10. Pivot Pin	21737	21737	21737					
<b>Suitable Pipe Connections</b>								
Inlet Banjo Bolt	7964	7964	7964					
Inlet Banjo Bolt	10543	10543	10543					
Repair Kit	★ KL.71486	KL.71486	KL.71470					

Boots are not included in any Assemblies and therefore must be ordered separately if required.

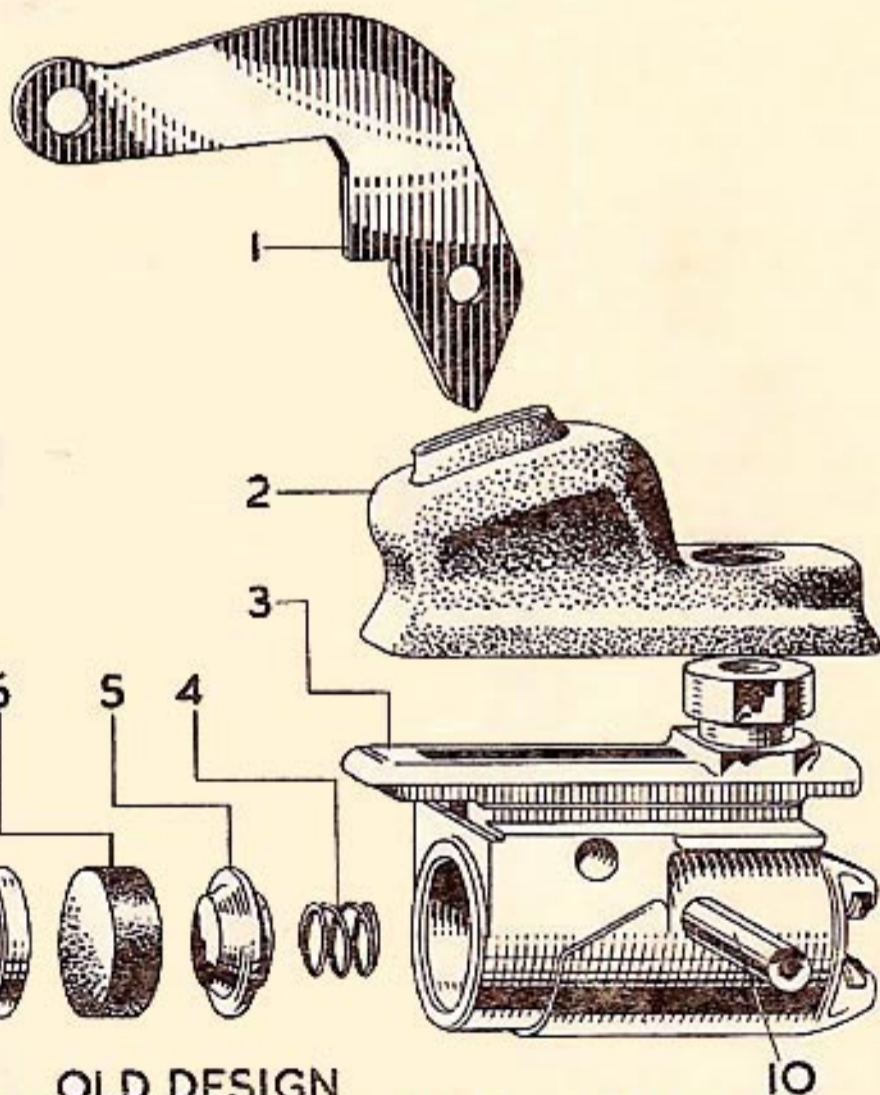

**OLD DESIGN**

**25453 (BX11) Rear wheel cylinder 401-4 & Arnolt, is the same as 28175 (BX7) except for the handbrake lever. This was replaced by 34348 (BX14 - below) and was listed for Austin, Alvis, Beardmore, Boydell, Lancing-Bagnell, Morris Commercial, Wales & Edwards, Wolseley.**

**NOTES**

- † When replacing a complete assembly always use new design, Assembly No. 33668 (Fig. BX12). Individual items of old design will not interchange with new.
- \* When replacing a complete assembly always use new design, Assembly No. 34577 (Fig. BX13). Individual items of old design will not interchange with new.
- † When replacing a complete assembly always use new design, Assembly No. 34348 (Fig. BX14). Individual items of old design will not interchange with new.
- †† When replacing a complete assembly always use new design, Assembly No. 36018 (Fig. BX17). Individual items of old design will not interchange with new.
- \*\* Handbrake Lever supplied by Vehicle Manufacturer.

# WHEEL CYLINDER INTERNAL SINGLE-ENDED

(with Handbrake)—continued



Figure  
**BX**

VOLUME 2. Page 23

## NEW DESIGN

Description	BX12— $\frac{7}{8}$ "	BX13— $\frac{7}{8}$ "	***** BX14— $1\frac{1}{8}$ "	BX15— $\frac{7}{8}$ "	BX16— $1\frac{1}{8}$ "	BX17— $\frac{7}{8}$ "	BX18—1"	BX19— $1\frac{1}{8}$ "	BX20— $1\frac{1}{8}$ "
	Part No.	Part No.	Part No.	Part No.	Part No.	Part No.	Part No.	Part No.	Part No.
Assembly	33668	34577	34348	36647	38976	36018	83287	84622	92197
1. Handbrake Lever	33674	33674	38986	36646	39147	36017	38986	*	*
2. Boot	33743	33743	35415	33743	35415	33743	35415	35415	35415
3. Cylinder Body	33673	33673	33970	33673	33970	33673	83286	84621	33970
4. Spring	29368	29368	30977	29368	30977	29368	29368	30977	30977
5. Cup Filler	29574	29574	29660	29574	29660	29574	30053	29660	29660
6. Cup	586	586	2762	586	2762	586	131	30149	2762
7. Piston (Hydraulic)	21692	21692	21735	21692	21735	21692	35207	21735	21735
8. Sealing Ring	93858/14	93858/14	93858/19	93858/14	93858/19	93858/14	93858/17	93858/19	93858/19
9. Piston and Dust Cover	36332	36467	38219	36332	38219	36332	38261	38219	38219
10. Pivot Pin	36185	36185	21737	36185	21737	36185	21737	21737	21737
<b>Suitable Pipe Connections</b>									
Inlet Banjo Bolt	21992	21992	7964	21992	7964	21992	7964	27175	7964
Inlet Banjo Bolt	94011	94011	10543	94011	10543	94011	10543	10543	10543
Repair Kit	KL.71506	KL.71506	KL.71518	KL.71506	KL.71518	KL.71506	KL.71541	KL.71554	KL.71518

Note—\*Handbrake Lever supplied by Vehicle Manufacturer.

Boots are not included in any Assemblies and therefore must be ordered separately if required.

**BX14 34348 assembly would seem to be the substitute for 25453 rear wheel cylinder but using your existing handbrake lever.**

