

MASTER CYLINDERS

INTERCHANGEABILITY LIST & BUYERS' GUIDE

(Continued)

Page 50. VOLUME 2



Assembly Number	Cylinder Dia.	Fig.	Repair Kit	APPLICATION	Alternative Master Cylinders (less Push Rod except where indicated thus ●)
* 80715	1"	NO.1	KL.71504	Beardmore, Bristol, Jaguar	
80860	—	—	—		(91620)●
81086	—	—	—		(91623)●
81286	—	—	—		(91617)●
81680	—	—	—		(88840)
83161	1 1/8"	NX.1	KL.71548	Humber	
83192	—	NG.11	KL.71566	Austin, M.C.C.	
83193	—	NG.12	KL.71526	Austin, M.C.C.	
83381	—	—	—		(91627)●
83382	—	—	—		(91624)●
83438	—	—	—		(84257)
83979	—	—	—		(97353)
83981	—	—	—		(97354)
84257	1"	NG.15	KL.71530	Dodge	
84655	1 1/8"	NM.4	KL.71492	Bedford	
84656	—	—	—		(84655)
84846	—	—	—		(83192)
84847	—	—	—		(83192)
85313	—	—	—		(92278)
85447	—	—	—		(87028)
85448	—	—	—		(87029)
85487	1"	NB.8	KL.71550	Wolseley	
85616	—	—	—		(92744)
85794	1 1/2"	NK.11	KL.71414	Dodge	
86906	1 1/4"	NK.12	KL.71483	Dodge, Soumen	
86907	—	—	—		(86906)
87028	—	—	—		(91625)●
87029	—	—	—		(91626)●
87298	—	—	—		(88702)
87299	—	—	—		(88187)
87584	—	—	—		(86906)
88187	7/8"	NG.1	KL.71408	Austin, Clifford Aero & Auto, Cooper, Coventry-Climax, Electruck, Fairthorpe, Lansing-Bagnall, Lancaster-Electric, Manuletric, M.C.C., M.G., Morris, Morrison Electricars, N.V. "Nemo", Singer, Tomlinson Electric, Wales & Edwards, Wolseley, Invacar, Morris, Ransome Simms & Jeffries	
88702	7/8"	NG.3	KL.71409		
88704	—	—	—		(88795)
88795	7/8"	NB.3	KL.71408	Riley, Wolseley	
88839	—	—	—		(88840)
* 88840	1"	NG.6	KL.71410	Allard, Alvis, Armstrong-Siddeley, Austin, Boydell, Bristol, Conveyancer, Coventry-Climax, Frazer-Nash, Harbilt, International Harvester, Kirby & West, Lister, M.C.C., Morrison-Electricars, Seddon, Trojan, Yale & Towne	

MASTER CYLINDER INTEGRAL BARREL TYPE

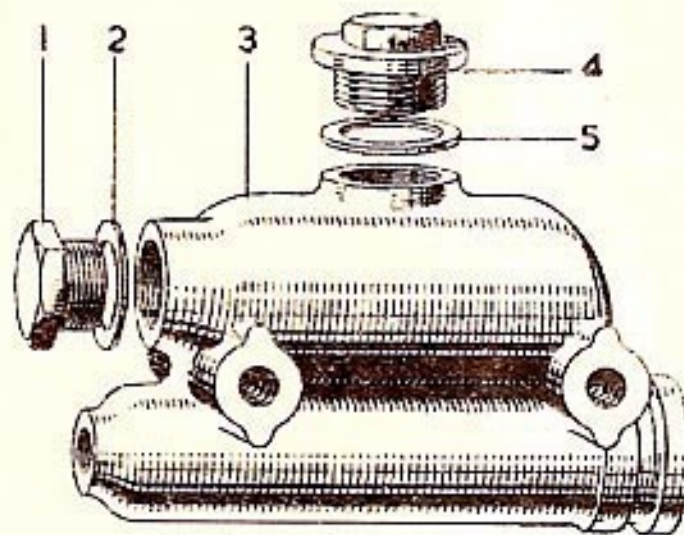

NG6 is listed as being fitted to all cars from 400 - 405 but not 404's, (NO1)

NG6 is also listed for 406's but there is some possible doubt about this as some 406's may have been fitted with the NO1 404 cylinder, although this may have been a later modification.
TO BE VERIFIED LATER.

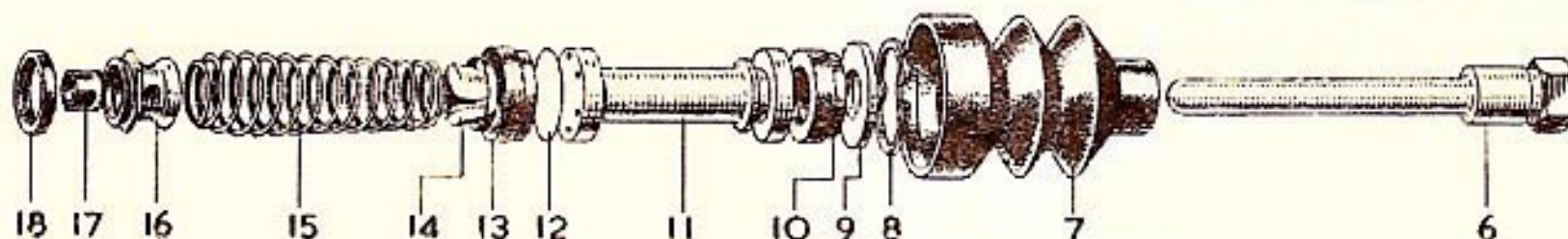

Bristol

Description	NG1— $\frac{1}{2}$ "	NG2— $\frac{1}{2}$ "	NG3— $\frac{1}{2}$ "	NG4—1"	NG5—1"	NG6—1"
	Part No.	Part No.	Part No.	Part No.	Part No.	Part No.
Assembly (less Push Rod) ---	88187	28707	88702	28708	28709	88840
1. Drain Plug ---	†23558	†23558	†23558	†23558	†23558	†23558
2. Gasket ---	KL.44542	KL.44542	KL.44542	KL.44542	KL.44542	KL.44542
3. Cylinder Barrel and Tank ---	‡25501	‡25501	‡28926	‡28928	‡28928	‡28928
4. Filler Plug ---	89833	†15097	89833	†15097	23814	89833
5. Gasket ---	87240	KL.44547	87240	KL.44547	KL.46141	87240
6. Push Rod ---			See Vehicle Application			
7. Boot ---	★ 437	437	22309	437	437	437
8. Spring Circlip ---	KL.47011	KL.47011	KL.47010	KL.47011	KL.47011	KL.47011
9. Stop Washer ---	1002	1002	22345	1002	1002	1002
10. Secondary Cup ---	★ 87366	87366	87366	400	400	400
11. Piston ---	21407	21407	2378	21421	21421	21421
12. Piston Washer ---	★ 90865	90865	90865	27979	27979	27979
13. Main Cup ---	★ 588	588	588	112	112	112
14. Spring Retainer ---	90839	90839	90839	431	431	431
15. Spring ---	21410	21410	38707	21412	21412	21412
16. Valve Body ---	2379	2379	2379	3589	3589	3589
17. Valve Cup ---	★ 108128	108128	108128	108128	108128	108128
18. Valve Washer ---	★ 27591	27591	27591	3590	3590	3590
Valve Assembly ---	★ *100795	*100795	*100795	**3830	**3830	**3830
Filler Extension ---	---	---	---	---	12640	---
Locknut ---	---	---	---	---	23905	---
Gasket ---	---	---	---	---	24712	---
Suitable Pipe Connections						
Outlet Banjo Bolt ---	94011	94011	94011	7964	7964	7964
" " " " ---	21992	21992	21992	10543	10543	10543
" " " " ---	25304	25304	25304	8048	8048	8048
Adaptor ---	25611	25611	25611	18327	18327	18327
Repair Kit ---	★ KL.71408	KL.71408	KL.71409	KL.71410	KL.71410	KL.71410

Continued

Notes: † Earlier Master Cylinders (as illustrated) fitted with 8334 Drain Plug, $\frac{1}{2}$ " dia. Hex. Head. Drain Plug, No. 23558 has a 1" dia. Round head.
‡ Check dimensions before ordering replacements.
§ Includes Drain Plug Ref. 1, and Gasket Ref. 2.

* Comprises items 16 and 17.
** Comprises items 16, 17 and 18.
†† Use Banjo Bolt, Part No. 237 with Filler Adaptor, Part No. 15097.



MASTER CYLINDER TANDEM TYPE

(With Tilting Valves)

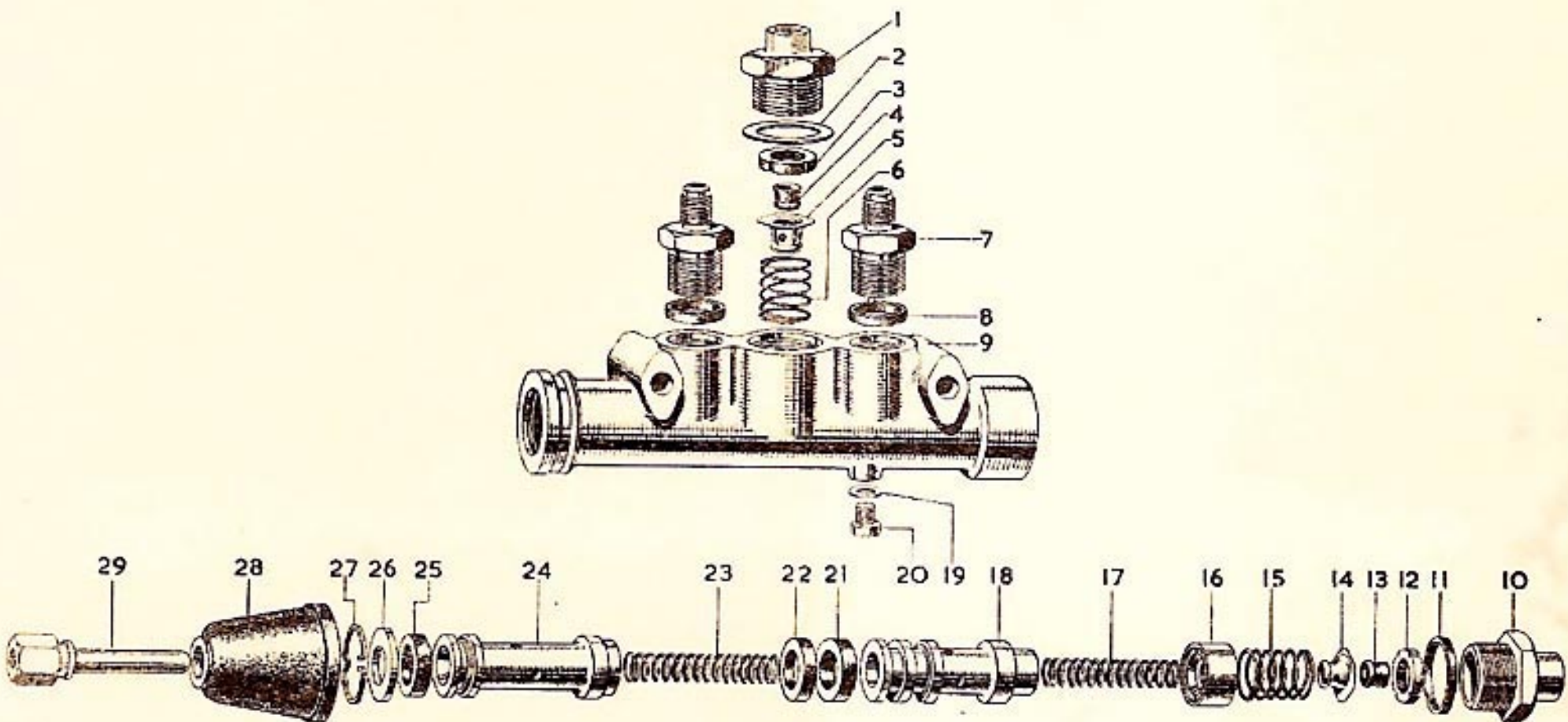

Bristol

Description	NO1—1"		NO2—1"	
		Part No.		Part No.
Assembly (less Push Rod)	---	80715	---	31031
1. Outlet Adaptor	---	30835	---	30835
2. Gasket	---	33443	---	33443
3. Valve Washer	---	5966	★	5966
4. Valve Cup	---	108128	★	108128
5. Valve Body	---	2379	---	2379
6. Valve Spring	---	6714	---	6714
7. Inlet Adaptor (with valve) (2)	---	38925	---	38925
8. Seal (2)	---	31592	★	31592
9. Cylinder Body	---	30828	---	30828
10. Outlet Adaptor	---	30835	---	30835
11. Seal	---	31593	---	31593
12. Valve Washer	---	5966	★	5966
13. Valve Cup	---	108128	★	108128
14. Valve Body	---	2379	---	2379
15. Valve Spring	---	6714	---	6714
16. Stop	---	30834	---	30834
17. Spring	---	31649	---	30831
18. Secondary Piston	---	31648	---	30830
19. Washer	---	KL.44509	---	KL.44509
20. Stop Pin	---	32964	---	32964
21. Seal	---	30832	---	30832
22. Seal	---	30832	---	30832
23. Spring	---	31649	---	30831
24. Primary Piston	---	31647	---	30829
25. Seal	---	30832	---	30832
26. Stop Washer	---	1002	---	1002
27. Spring Circlip	---	KL.47012	---	KL.47012
28. Boot	---	24995	★	24995
29. Push Rod	---	See vehicle application	---	---
Repair Kit	---	★ KL.71504	---	★ KL.71504

**SUITABLE
PIPE
CONNECTIONS**

Outlet Banjo Bolt,
Part No. 10543

Tube Nut (Inlet),
Part No. 18234