

# DYNAMOS AND CONTROL BOXES

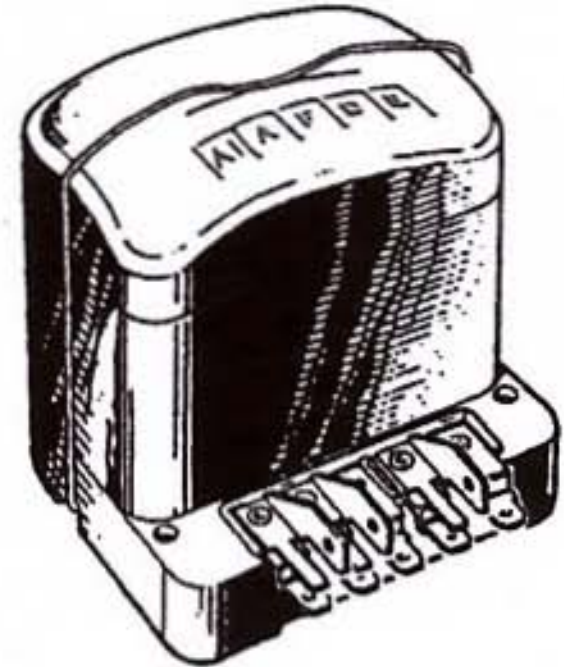
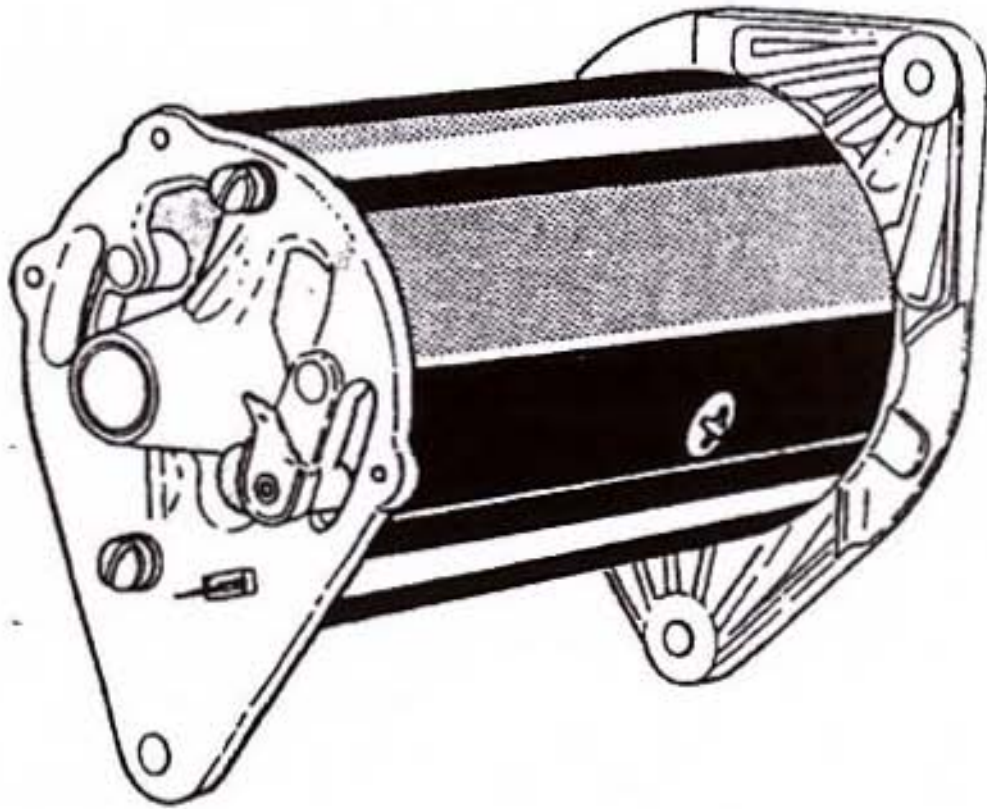
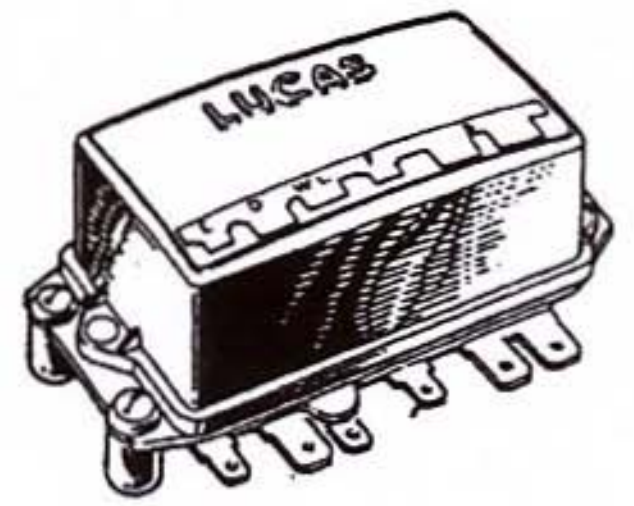

## INTRODUCTION

The D.C. charging system is designed to maintain the battery in a reasonable state of charge under average running conditions.

This means that the dynamo output must be sufficient to supply the normal continuous vehicle electrical load plus the little extra required to keep the battery charged.

The inherent design of the dynamo is such that it must always be under some form of control, both to protect the machine against overload and to protect the battery against overcharge.

A control box, therefore, is designed to operate with a specific type of dynamo on a given application.

For many years the "Compensated Voltage Control" (2-bobbin) system has been employed, and in fact is still used on certain present-day production vehicles. However, with the increase in electrical equipment fitted to the modern vehicle, it became necessary to utilise a system better suited to present-day requirements. This brought about the "Current Voltage Control" (3-bobbin) system. The main advantage of this system is that it allows maximum safe dynamo output for a longer period of time when the battery is in a discharged condition.

Dynamos or control boxes may be replaced as individual units provided two rules are strictly observed.

1. That the *correct* replacement unit is fitted
2. That, after fitting, the test procedure is carried out on *both* units to ensure that the complete system is operating efficiently.

## TEST 1. Battery Test

Using a hydrometer, check that the battery is at least 70% charged and in good condition, see Fig. 55.

A battery fault can have an adverse effect on the charging system. For example, a sulphated battery will produce low charge rate whereas a battery with a shorted cell will produce high charge rate.

## CHECKING DYNAMO

### TEST 2. Drive Belt Tension

Allow 13–19 mm (0.5"–0.75") play when moderate finger pressure is applied to the longest run of the belt, Fig. 56.

The dynamo will not charge the battery if the drive belt is too slack. On the other hand, an excessively tight belt will damage the bearings.

If the belt is worn or oily it should be replaced.

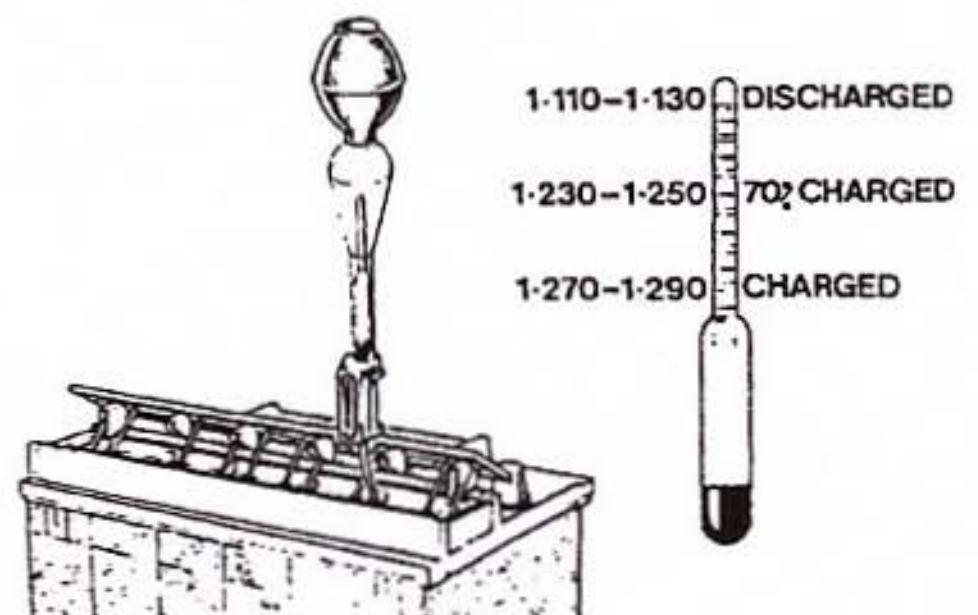

Fig. 55 Hydrometer test

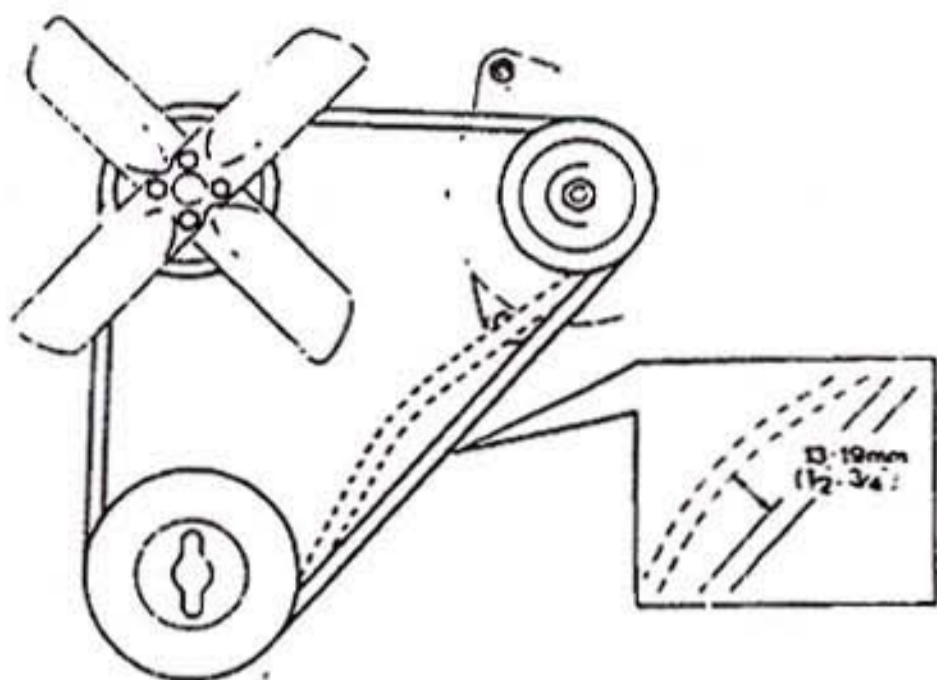

Fig. 56 Drive belt tension

### TEST 3. Testing the Armature Circuit

Disconnect the leads at the dynamo and connect the voltmeter between a good earth and the dynamo 'D' terminal, Fig. 57. Start the engine and slowly increase the speed to approx. 1,500 rev/min. The voltmeter should register 1.5-3.0V.

### TEST 4. Testing the Field Circuit

The voltmeter is kept in the same position as for the previous test (between terminal 'D' and earth), and an ammeter is connected between 'D' and 'F', Fig. 58. The engine speed is increased slowly, until the voltmeter registers nominal battery voltage (usually 12V). The ammeter should then read approx. 2A.

If the ammeter indicates a higher current, the field resistance is low.

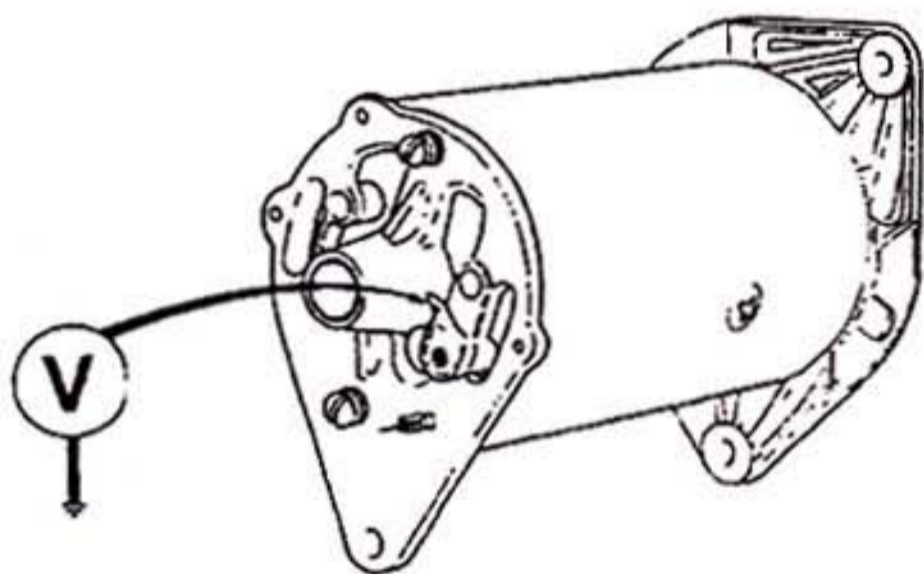

Fig. 57 Testing the armature circuit

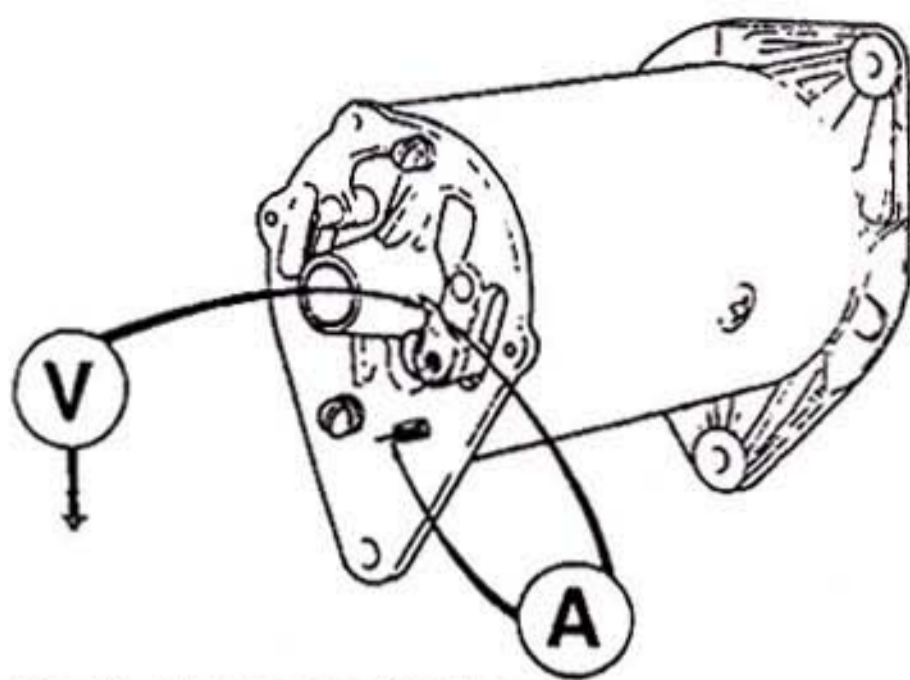

Fig. 58 Testing the field circuit

### TEST 5. Checking Dynamo Leads

If the correct readings are obtained on the tests at the dynamo, the fault could be in the wiring between dynamo and control box. To prove these cables, test as follows: Re-connect the leads at the dynamo and disconnect 'D' and 'F' at the control box. Connect one lead of the voltmeter to earth, the other to the 'D' lead, Fig. 59, and run the engine at charging speed. The reading should be the same as at 'D' on the dynamo (1.5-3.0V). No reading indicates a faulty 'D' lead, a high reading indicates a short between the 'D' and 'F' cables.

If the reading is correct, leave voltmeter in position ('D' to earth) and short 'F' lead to 'D' lead. Voltmeter needle should rise with increasing speed. If the reading increases only slightly, an open-circuit 'F' lead is indicated. A zero reading denotes 'F' lead shorted to earth.

### COMPENSATED VOLTAGE CONTROL

#### TEST 6. Open-Circuit Voltage Setting

Re-connect 'D' and 'F' leads to control box. Remove the 'A' and 'AI' leads and join the two together (Fig. 60). Connect the voltmeter between terminal 'D' and earth, and run the engine up until voltmeter settles. Increase speed slightly and then regulation should take place within the limits: 16 to 16.5V.

If the voltmeter readings are outside the appropriate limits, the voltage setting must be adjusted by turning the adjustment screw at the back of the regulator frame. Turn the screw clockwise (or inwards) to increase the voltage, and anti-clockwise (or outwards) to reduce it.

If turning the adjustment screw has no effect on the voltage setting (reading off the scale), check for a faulty control box earth connection, or an open-circuit shunt winding.

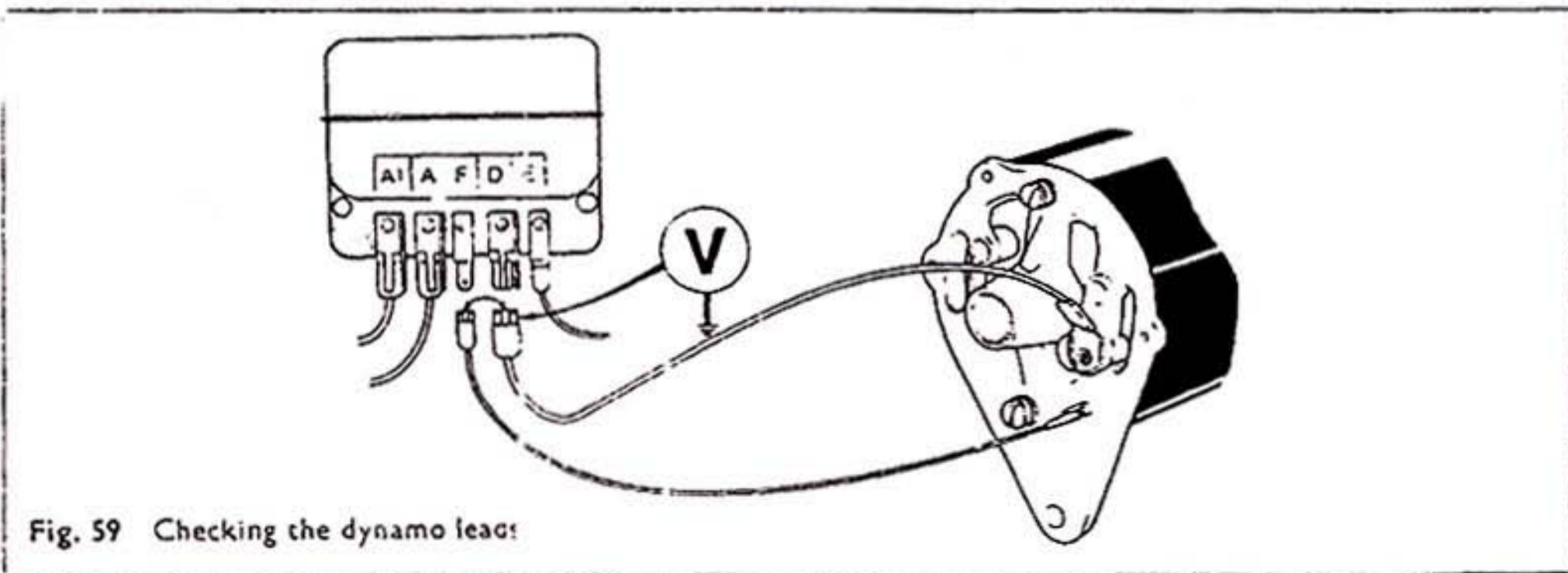
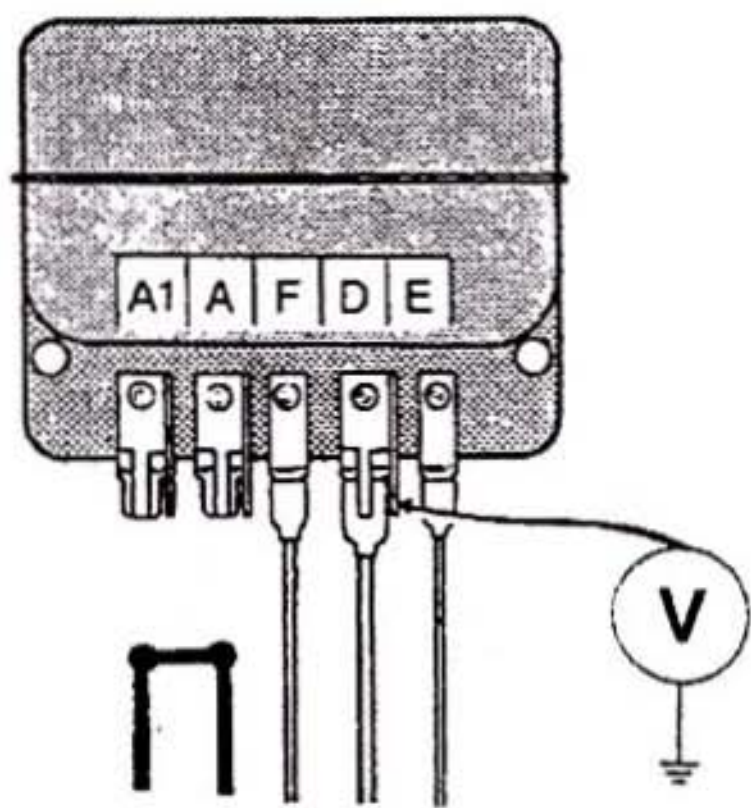

Fig. 59 Checking the dynamo leads



OPEN CIRCUIT VOLTAGE SETTING

Fig. 60 Checking the open circuit voltage setting

### TEST 7. Cutting-in Voltage

Next, the cutting-in voltage must be checked (Fig. 61). Connect an ammeter between the control box 'A' terminal and the leads which have been disconnected from the 'A' and 'A1' terminals. The voltmeter is kept in the same position, between the 'D' terminal and earth. Switch on headlights. Start the engine and gradually increase the speed.

When the cut-out points close the voltmeter needle will kick back. This should occur within the limits 12.7-13.3V. If it does not, the cut-out setting should be adjusted by means of the adjusting screw at the back of the cut-out. Adjust with engine stationary and repeat test.

Increase the engine speed. The ammeter reading should increase with speed. (The actual reading will depend on the state of the battery charge and the electrical load).

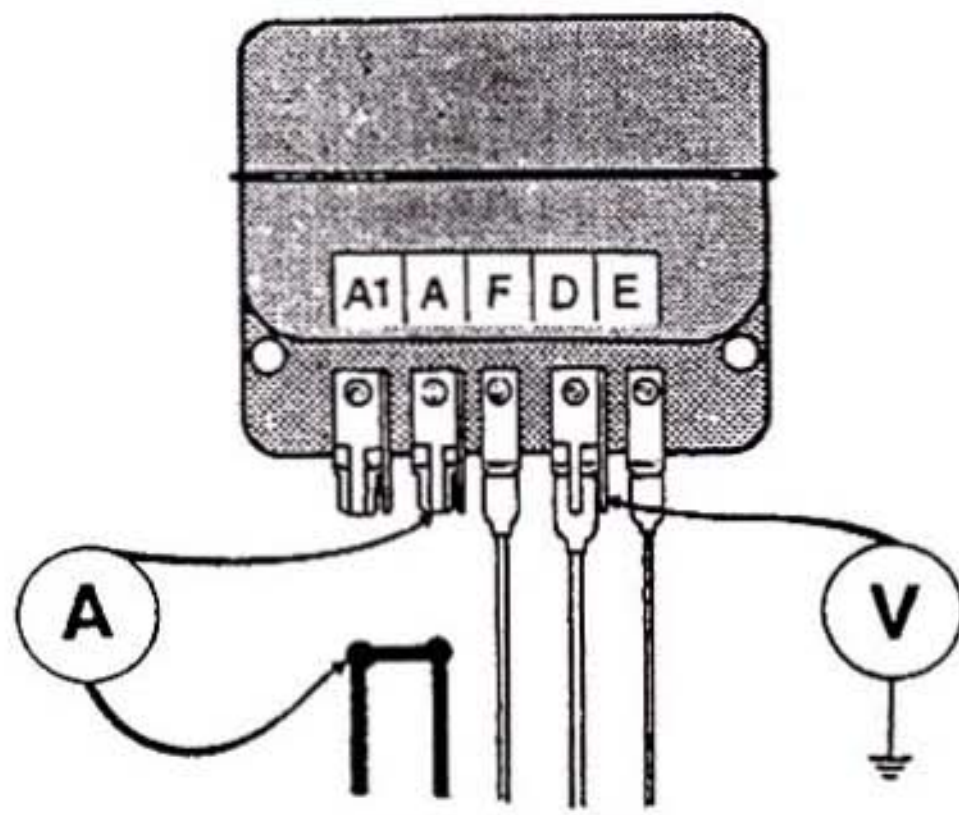

CUTTING IN VOLTAGE

Fig. 61 Checking the cutting-in voltage

Gradually reduce the engine speed. The ammeter needle should fall until it indicates a discharge (or reverse) current of 3-5 amps. The ammeter needle should return to zero when the cut-out points open. Replace all control box leads, ensuring correct connections.

### TEST 8. Checking Voltage Drop on Supply Line

Remove the 'D' lead from the dynamo terminal and connect the ammeter into the circuit, see Fig. 62.

Connect the voltmeter between the dynamo 'D' lead (removed) and the battery supply terminal at the starter solenoid.

Start and run the engine at charging speed until the ammeter reads 10A. At this point the voltmeter reading should not exceed 0.75V.

A higher reading than 0.75V denotes a high resistance in the insulated circuit.

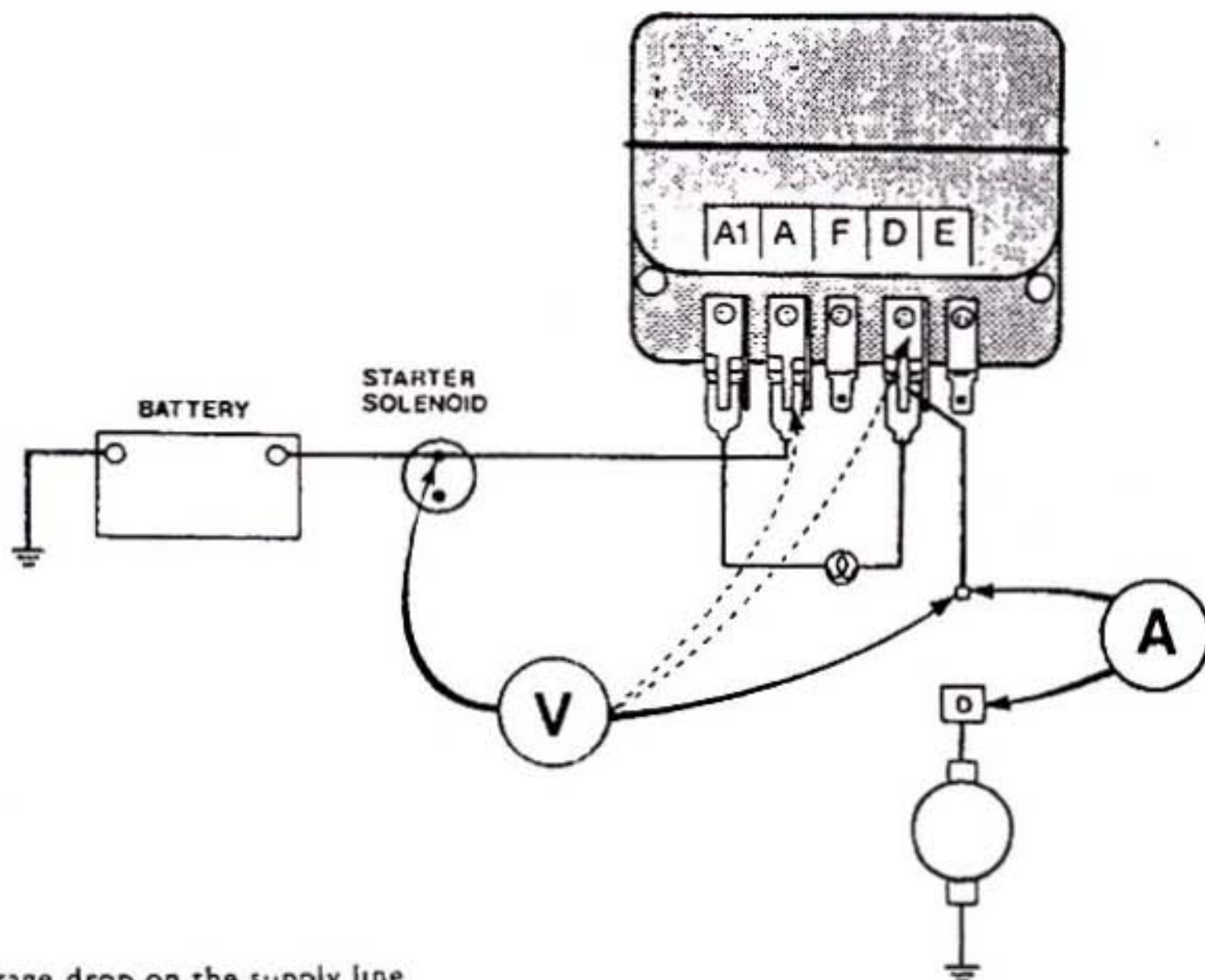

Fig. 62 Voltage drop on the supply line

## IGNITION WARNING LIGHT

The "Ignition Warning Light", to use its more popular name, has two basic functions.

Primarily, to indicate that the ignition is switched on and secondly, when the engine is started and the rev/min increased, it should fade and "go out". This indicates that the dynamo voltage has risen sufficiently to close the cut-out switch between dynamo and battery.

**Note:** The fact that the light goes out does *not* necessarily mean that the charging system is functioning correctly.

One side of the bulb is connected to the output terminal of the ignition switch and the other side to the 'D' terminal, usually done at the control box 'D' terminal, as shown in Fig. 63.

With the ignition on and the engine stationary, battery voltage is applied to one side of the warning light via the ignition switch. The other side is connected to earth via the dynamo armature and brush-gear.

When the engine is started and the rev/min increased, voltage from the dynamo 'D' terminal rises at one side of the bulb to oppose battery voltage at the other side. The warning light then fades until both voltages are equal, when it is completely extinguished. At almost the same instant the cut-out points close (13V) thus shorting out the warning light and allowing the bulb to remain out.

A warning light that "glows" faintly under normal running conditions can be due to any of the following faults.

1. Internal high resistance in the ignition switch
2. Dirty control box cut-out contacts.
3. A slipping fan belt (if slipping badly enough)

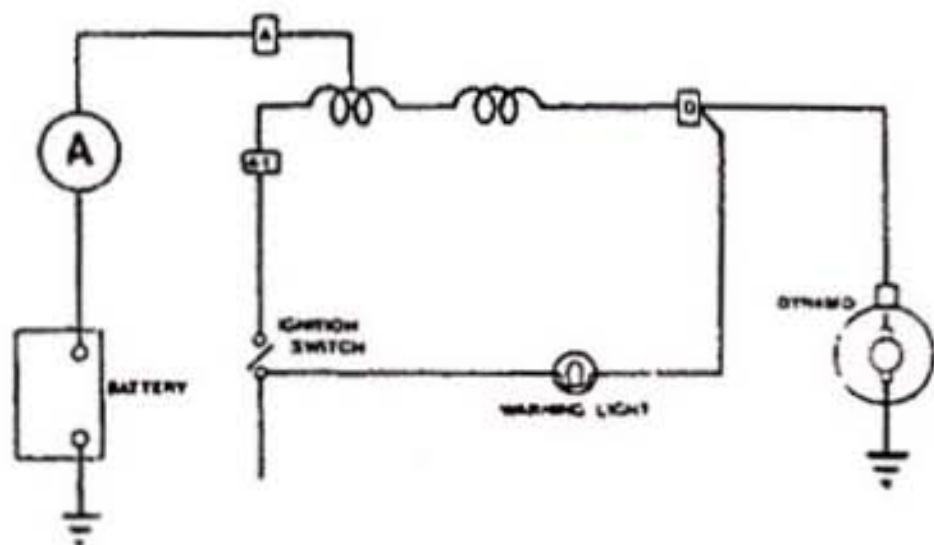

Fig. 63 Ignition warning light circuit

## CURRENT VOLTAGE CONTROL

### TEST 1. Voltage Regulator Setting

Remove the leads from the 'B' terminal (if more than one, join them together).

Connect a voltmeter between the 'D' terminal and earth, (Fig. 64), and run the generator up to a stable running speed, normally about 3,000 rev/min.

If the voltmeter readings are outside the appropriate limits, the cover must be removed and the voltage regulator setting adjusted by means of the special tool.

A regulator checked and found to be stable at not more than 0.5V above or below the checking limits (see table) must be re-set to the nearest outside limit (high or low). If the setting is more than 0.5V outside the limits, the regulator can be considered faulty and should be replaced.

The regulator must be adjusted by means of the special tool.

**Note:** Boxes under warranty should be replaced

Ambient Temperature	O.C. Voltage Checking	If Between	Reset to
0°-25°C (32°-77°F)	14.5-15.5	14.0-14.5 15.5-16.0	14.5 15.5
26°-40°C (78°-104°F)	14.25-15.25	13.75-14.25 15.25-15.75	14.25 15.25

### TEST 2. Cutting-in Voltage

The cutting-in voltage is checked as shown in Fig. 65. Connect an ammeter between the 'B' leads and the 'B' terminal on the control box. Keep the voltmeter in the same position as the previous test (between terminal 'D' and earth). Switch on headlights. Start the engine and gradually increase the speed.

When the cut-out points close, the voltmeter needle will kick back. This should occur within the limits 12.7-13.3V. If it does not, the cut-out setting should be adjusted by means of the adjustment screw at the back of the cut-out frame (6GC) or special tool (RB340).

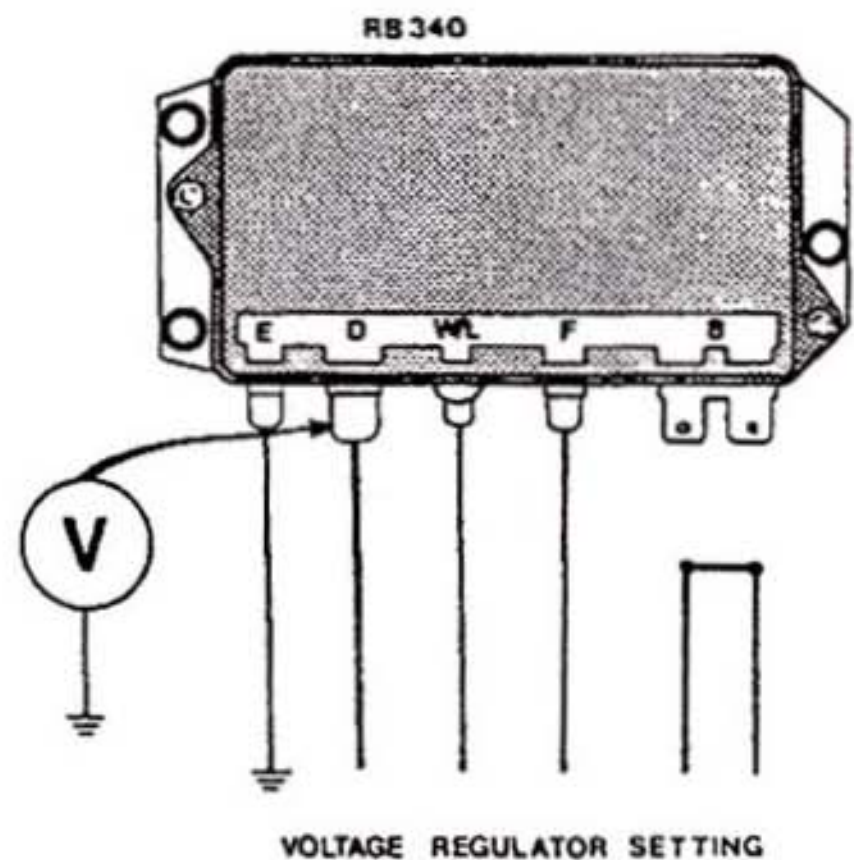

Fig. 64 Checking the voltage regulator setting

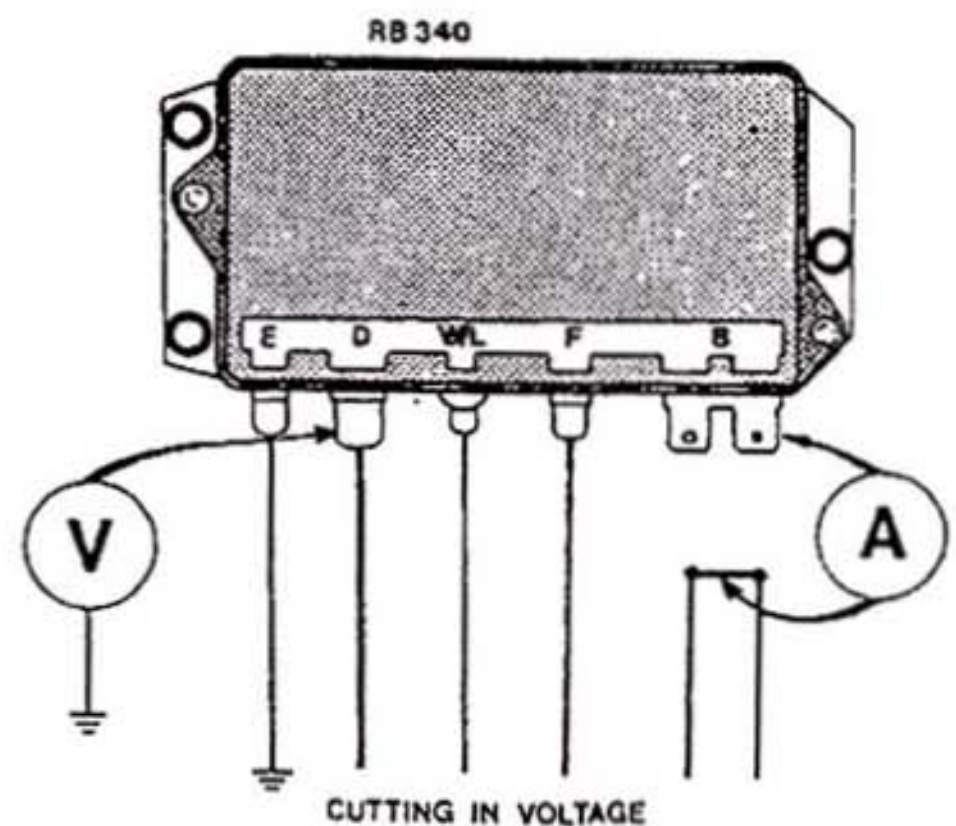

Fig. 65 Checking the cutting-in voltage

Increase the engine speed and the reading on the ammeter should increase with speed, (dependent on state of battery charge and electrical load).

Gradually reduce the engine speed. The ammeter needle should fall until it indicates a discharge (or reverse) current of 3-10 amps. The ammeter needle should return to zero when the cut-out points open

### TEST 3. Current Regulator Setting (Fig. 66)

For the purpose of this test the dynamo must produce its safe maximum output regardless of the state of charge of the battery, therefore the voltage regulator must be made inoperative.

This is achieved by connecting a crocodile clip across the voltage regulator contacts.

Switch off all lights (from previous test).

With the ammeter still in position (connected in series with 'B' lead) start the engine and increase the rev/min to just above charging speed. The meter reading should correspond to the figure shown in the table for a given dynamo.

Associated dynamo	Nominal Setting $\pm 1$ amp
C40/1 (4½" dia. fan)	19A
C40/1 (5" dia. fan)	22A
C40A	10.5A
C40L	25A
C42	30A
C40T (except Part No. 22762)	22A
C40T (Part No. 22762)	18A

Method of adjustment is similar to voltage regulator and cut-out.

In the case of boxes under warranty where the cover should *not* be removed, the following alternative methods of checking may be used.

Switch on headlights and leave on for 5 minutes before starting engine.

Still with the headlights on, start and run engine at above charging speed, check ammeter reading. If incorrect to specifications quoted, replace box.

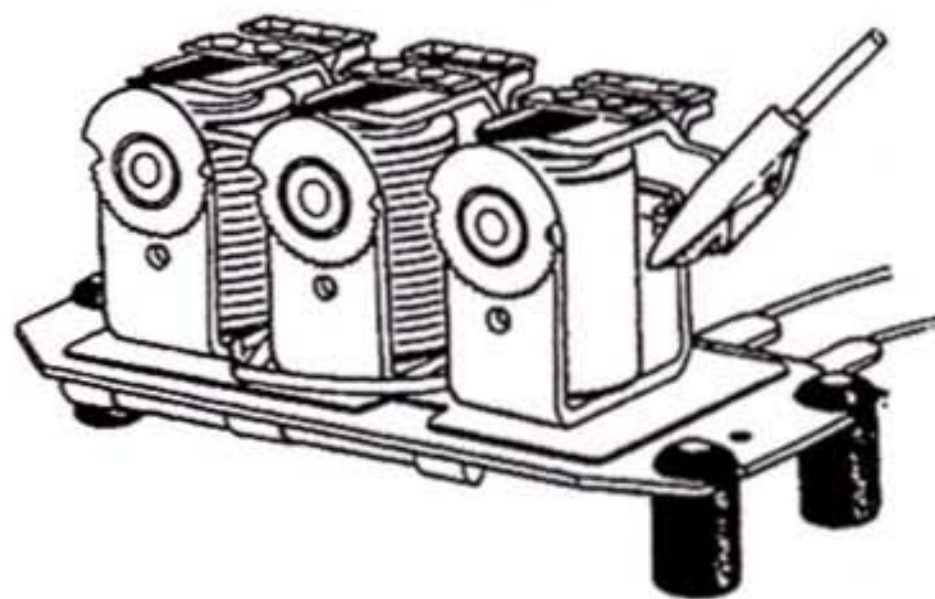

Fig. 66 Checking the current regulator setting

### TEST 4. Checking Voltage Drop on Supply Line

Remove the 'D' lead from the dynamo terminal and connect the ammeter into the circuit, see Fig. 67.

Connect the voltmeter between the dynamo 'D' lead and the battery supply terminal at the starter solenoid. Start and run the engine at charging speed until the ammeter reads 10A. At this point the voltmeter reading should not exceed 0.75V.

A higher reading than 0.75V indicates a high resistance in the insulated line.

### CONCLUSION

Having obtained an idea of the various forms of generator control units and their working, it may be desirable to add a note of caution.

The successful servicing of these important components depends on making adjustments which are stable and permanent. Only a limited amount of work can be successfully executed in the general garage. If, for example, a control unit will not respond to the adjustments outlined, it should be replaced.

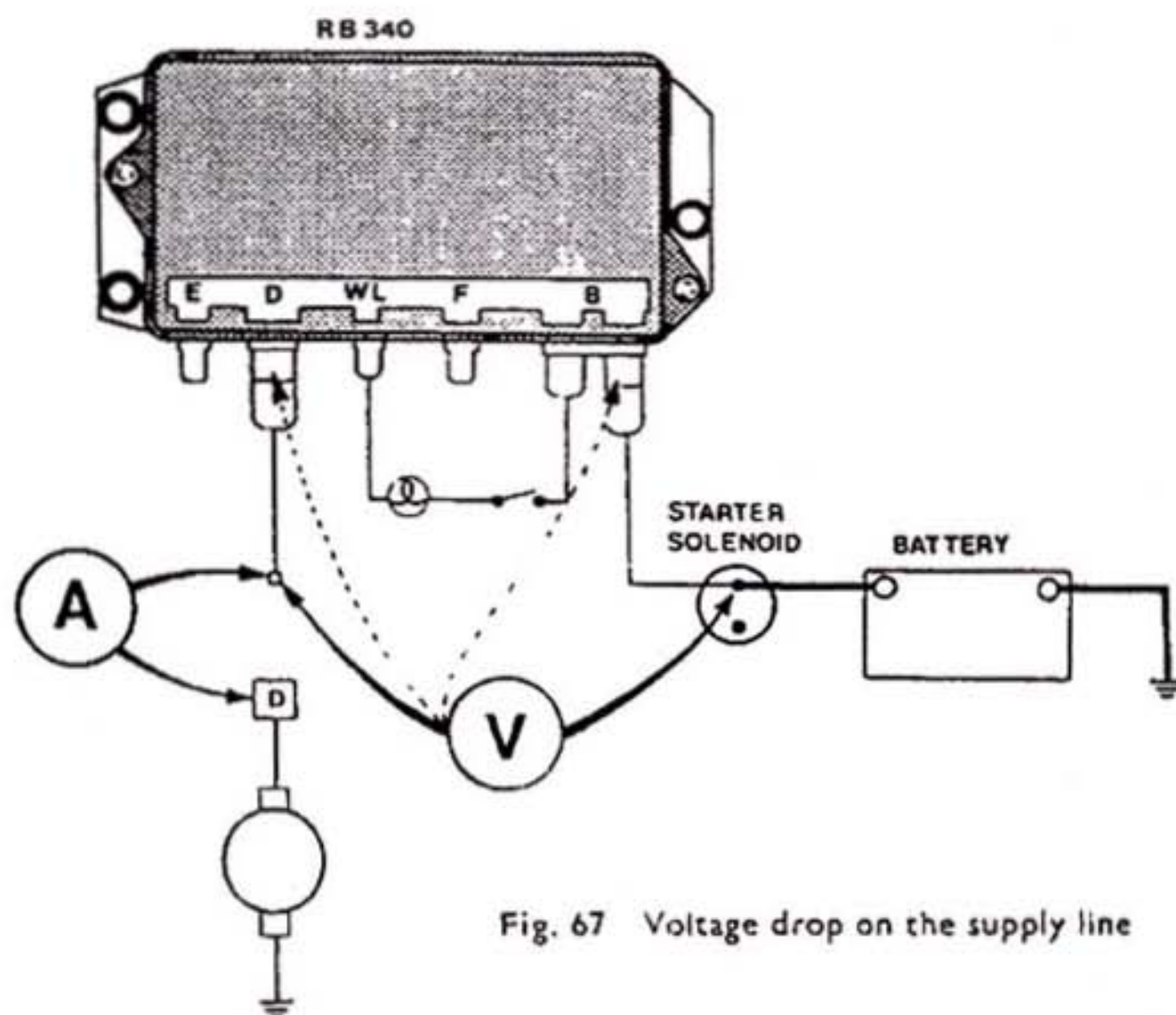

Fig. 67 Voltage drop on the supply line